

# 24hr Emergency Repair Service

Whatever the problem or make of door, our professional engineers are on call 24hrs a day to assist you. Our dedicated staff will offer a speedy response to any call for assistance, an experienced engineer will repair or make secure any door and advise any further improvements or replacements that may be required.

FOR MORE INFORMATION CALL:

# 01698 376 444



# LOWLAND ENSOR

## Designed with your requirements in mind...

*Our complete range of doors are expertly designed and competitively priced, without compromising quality.*

### ROLLER SHUTTERS & GRILLES

Low maintenance, security and a range of finishes makes this popular door a bestseller. Options now available include: perforated, punched matrix designs and insulated lath.

Our range of rolling and folding grilles in aluminium, plastic, steel or wood, will enhance as well as secure your bar, servery, precinct, shop or office.

### SECTIONAL OVERHEAD DOORS

Aesthetically pleasing Insulated Overhead Doors are designed for today's energy conscious buildings. Available with a variety of glazing options from single viewing panel to totally glazed door.

### HINGED STEEL DOORS

There is a steel hinged door to suit every application: security, general purpose, acoustic, glazed louvered and fire rated. Standard ironmongery or fitted with your choice of hardware.

### HIGH SPEED RAPID ROLLERS

Another door for the energy conscious, a fabric or PVC secondary door which operates in under 2 metres per second, keeping valuable heat in.

Rubber doors are also popular, when it comes to energy saving these 'Crash' doors come in various combinations of rubber and PVC, in different thickness and strengths, to suit any pedestrian or vehicular traffic.

### BARRIERS & GATES

We offer a complete range of mechanical/electrical gates and barrier systems. Our comprehensive range of upgrade packages are design ed to suit a variety of different applications.

### SERVICE

Our experienced staff are on hand to provide repair and maintenance support of our full product range, regardless of make or manufacturer.

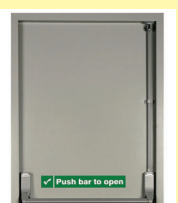
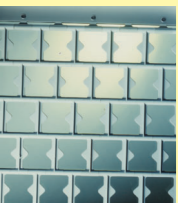

## ROLLER SHUTTER DOORS

# LOWLAND ENSOR

LOWLAND ENSOR DOORS LTD, 9 NETHERTON ROAD, WISHAW ML2 0EQ  
Telephone: 01698 376 444 Fax: 01698 376 888 Email: sales@lowlandensor.co.uk

## www.lowlandensor.co.uk



ENSOR GROUP

# ROLLER SHUTTER DOORS

# LOWLAND ENSOR

## Specifications and Technical Data

### 1. Endplate

Fabricated from mild steel plate and fixing angles to suit shutter size and type.  
Steel shoes or bearings fixed to endplates to accept barrel shaft.  
All steelwork primed and finished.

### 2. Barrel

Suitably sized steel tube housing torsion springs running on steel axle.

### 3. Curtain

Refer to page 3 for options and finishes.

### 4. Bottom Rail

Provided for strength and rigidity, and can accommodate various locking mechanisms.

### 5. Guides

Fabricated from aluminium or galvanised steel to suit curtain type. Various guide sizes and fixing arrangements available to suit face of wall fix and between wall fix applications. Windlock guides are provided on larger shutters.

### 6. Electric Motor

440 volt 3 phase motor complete with limit switches and manual over-ride.  
Single phase and tubular motors available on request.

### 7. Handchain Gearing

Single or double reduction spur gearing and continuous handchain designed to suit medium sized shutters.

### Complete Installation

Complete installation and repair service available.

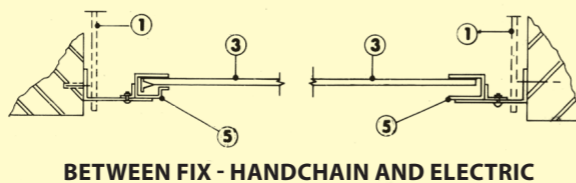
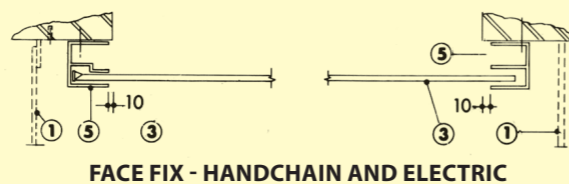
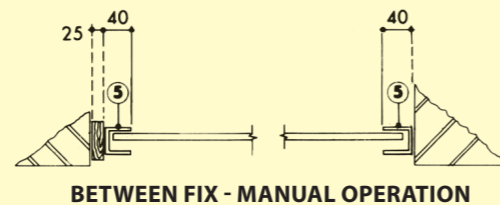
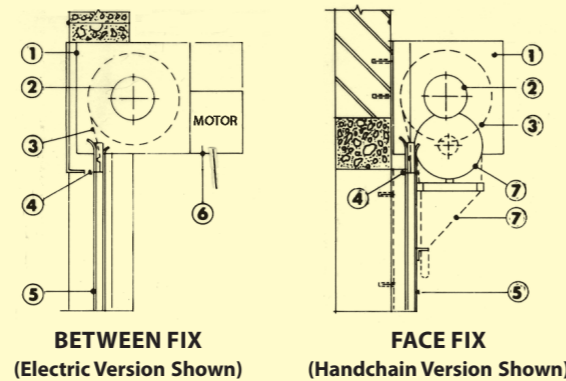

## Operation Options

For our roller shutters and doors, manual operation up to 9m<sup>2</sup>. Handchain or electric operation for over 9m<sup>2</sup>.

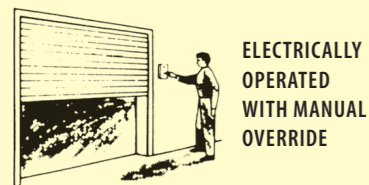

## Curtain Options and Finishes

### Traditional Roller Shutters

**STEEL:** Available in 76mm curved for 51mm flat interlocking galvanised lath sections, complete with endlocks to prevent lateral movement. A galvanised steel bottom rail is provided. **ALUMINIUM:** Constructed from 51mm mill finish aluminium with endlocks to prevent lateral movement. An aluminium bottom rail is provided.



### Perforated Shutter

Available in 76mm curved of 51mm flat interlocking steel sections with an embossed diamond pattern for added strength with aesthetic properties. A galvanised steel bottom rail is provided.



### Insulated Lath

Manufactured from twin skinned interlocking sections and in-filled with CFC free insulation to give a thermal value of 0.69w/m<sup>2</sup>k.

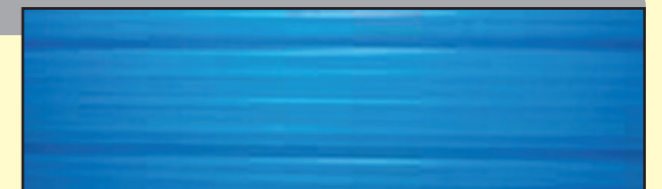

### Brickbond Grille

**STEEL:** Constructed from steel rods spaced horizontally at 70mm centres connected by zinc plated links and tubes. A galvanised steel bottom rail is provided for strength and rigidity. **ALUMINIUM:** Constructed from aluminium rods spaced horizontally at 70mm centres connected by aluminium links and tubes to form a 220 x 60 aperture. An aluminium double angle bottom rail is provided for strength and rigidity.

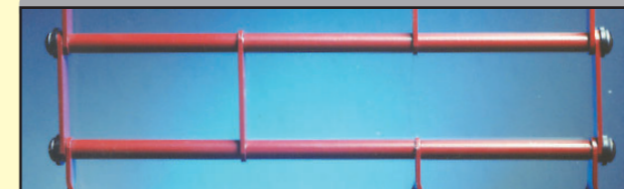

Our roller shutters and doors are available with the following finishes: **STEEL** - Plastisol, Powder Coating or **ALUMINIUM** - Anodising, Powder Coating.

## Optional Extras

### Hood

Made from pressed galvanised steel to form various profiles.



### Weather Seal

Rubber strip fitted to bottom rail to prevent draughts.

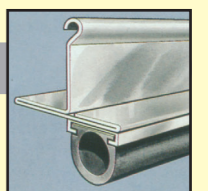

### Electrical Operation

All types of activation and control systems available.

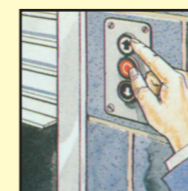

### Plastisol Bottom Rail

Now available in a limited range of colours to compliment a plastisol finished roller shutter door.



Call now for a **FREE** Survey/Quotation on:

**01698 376 444**



ENSOR GROUP

At Lowland Ensor we have a policy of progressive design and we reserve the right to change or modify our products without alteration to this leaflet.